

**SIEMENS**

## SINAMICS S120 系统中的编码器转换模块介绍

SINAMICS S120 Sensor Moudle Introdudcation

**Signal FAQ**

**Edition (2012年07月)**

**摘要** 本文介绍了 SINAMICS 120 系统中使用的编码器转换模块。

**关键词** S120, 编码器转换模块

**Key Words** S120, Sensor Module

## 目 录

1 概述.....	4
2 安装在机柜中的编码器信号转换模块.....	5
2.1 SMC10 模块（6SL3055-0AA00-5AA3）.....	5
2.2 SMC20 模块（6SL3055-0AA00-5BA3）.....	7
2.3 SMC30 模块（6SL3055-0AA00-5CA2）.....	10
3 安装在设备上的的编码器信号转换模块.....	13
3.1 SME20 模块（6SL3055-0AA00-5EA3）.....	13
3.2 SME25 模块（6SL3055-0AA00-5HA3）.....	14
3.3 SME120 模块（6SL3055-0AA00-5HA3）.....	15
3.4 SME125 模块（6SL3055-0AA00-5KA3）.....	18

## 1 概述

在 SINAMICS S120 驱动系统中，电机模块只能连接带 Drive-Cliq 通讯接口的编码器，如果电机不带 Drive-Cliq 通讯接口则需要将电机编码器连接到 SMC 或 SME 编码器信号转换模块上，将转换后的信号连接到电机模块上。S120 系统连接示例如图 1 所示：



图 1.S120 系统连接示例

编码器模块从安装形式上有用于安装在机柜中及安装在设备上的两种开式，分别为 SMC 及 SME 模块。

可连接的编码器类型：

Encoder systems	SMC			SME			
	SMC10	SMC20	SMC30	SME20	SME25	SME120	SME125
Resolver	Yes	-	-	-	-	-	-
Incremental encoder sin/cos (1 Vpp) with/without reference signal	-	Yes	-	Yes	-	Yes	-
Absolute encoder EnDat 2.1	-	Yes	-	-	Yes	-	Yes
Incremental encoder TTL / HTL	-	-	Yes	-	-	-	-
Absolute encoder SSI	-	Yes <sup>1)</sup>	Yes <sup>2)</sup>	-	Yes <sup>1)</sup>	-	Yes <sup>1)</sup>
Temperature evaluation	Yes	Yes	Yes	Yes <sup>3)</sup>	-	Yes (electrically isolated)	Yes (electrically isolated)

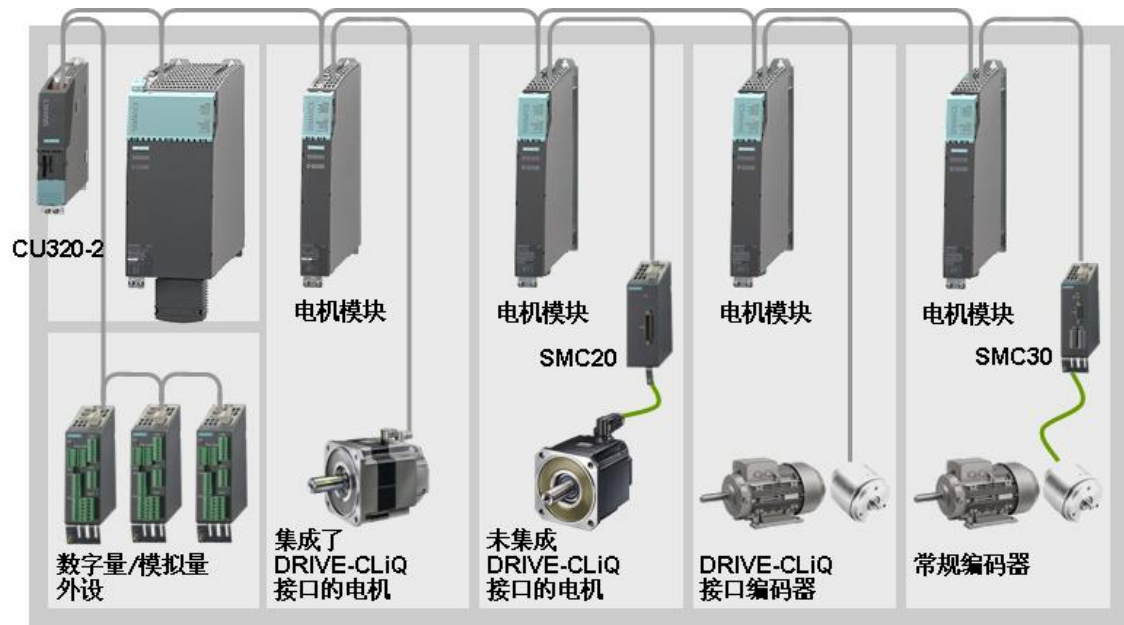
- 1) 仅可能用于 SSI 编码器 5 V 供电
- 2) 可用于 SSI 编码器 5 V 或 24V 供电
- 3) 需定制电缆 6FX8002-2CA88

## 2 安装在机柜中的编码器信号转换模块

机柜式安装的编码器信号转换模块(SMC)可以单独订购和配置。当没有配备带有 DRIVE-CLiQ 接口的电机或除电机编码器外还需要外部编码器时，可使用这种传感器模块。每个机柜安装式传感器模块(SMC)只能连接一个传感器系统。

注意：

SMC 为编码器提供电源；必须为SMC模块提供单独的24VDC电源。

### 2.1 SMC10 模块（6SL3055-0AA00-5AA3）

#### （1）模块概览



图 2. SMC10 概览

#### （2）可处理的编码器信号

- 2 极旋转变压器
- 多极旋转变压器

机柜安装式传感器模块 SMC10 通过 DRIVE-CLiQ 与控制器CU320 进行通讯。

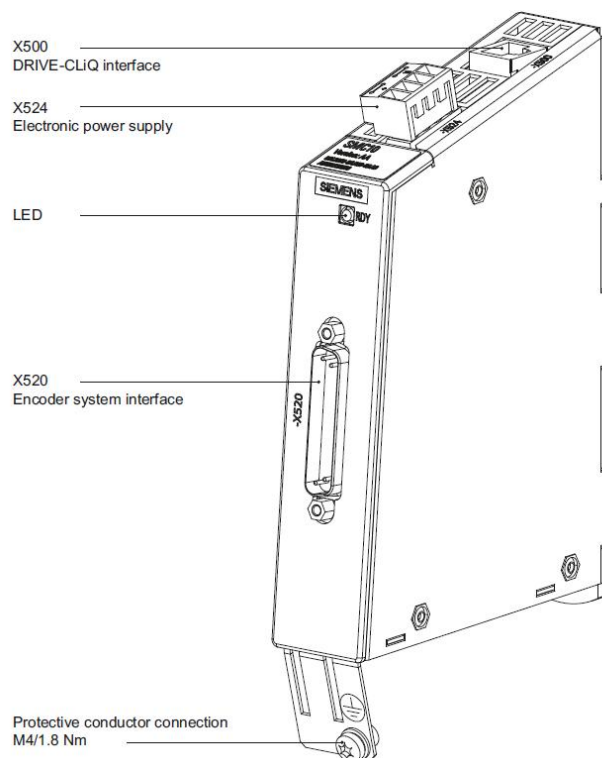
#### （3）设计

机柜安装式编码器模块 SMC10 标准提供有下列接口：

- 1 个 DRIVE-CLiQ 接口

- 1 个编码器接口，包括电机温度检测 (KTY84-130)，通过 Sub-D连接器连接
- 1 个电子装置电源接口，通过 24 V DC 电源连接器连接
- 1 个 PE ( 保护性接地) 接口

机柜安装式传感器模块 SMC10 的状态通过一个多色 LED 来显示。

机柜安装式传感器模块 SMC10 可以卡在符合 EN 50 022 标准的35 x 15 / 7.5 DIN 导轨上。

SMC10 模块和编码器之间的最大编码器电缆长度为：

- 可连接编码器最长电缆长度：130 m

(4) SMC10 X520 接口定义

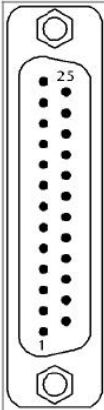
	Pin	Signal name	Technical specifications
	1	Reserved, do not use	
	2	Reserved, do not use	
	3	S2	Resolver signal A (sin+)
	4	S4	Inverted resolver signal A (sin-)
	5	Ground	Ground (for internal shield)
	6	S1	Resolver signal B (cos+)
	7	S3	Inverted resolver signal B (cos-)
	8	Ground	Ground (for internal shield)
	9	R1	Resolver excitation positive
	10	Reserved, do not use	
	11	R2	Resolver excitation negative
	12	Reserved, do not use	
	13	+ Temp	Motor temperature measurement KTY84-1C130 (KTY+) Temperature sensor KTY84-1C130 / PTC
	14	Reserved, do not use	
	15	Reserved, do not use	
	16	Reserved, do not use	
	17	Reserved, do not use	
	18	Reserved, do not use	
	19	Reserved, do not use	
	20	Reserved, do not use	
	21	Reserved, do not use	
	22	Reserved, do not use	
	23	Reserved, do not use	
	24	Ground	Ground (for internal shield)
	25	- Temp	Motor temperature measurement KTY84-1C130 (KTY-) Temperature sensor KTY84-1C130 / PTC

Connector type: SUB-D, 25-pole

(5) 模块连接示例



图 3. SMC10 连接示例

(6) 可评价的最大频率

Resolver		Max. speed resolver / motor		
Number of poles	Number of pole pairs	8 kHz/125 μsec	4 kHz/250 μsec	2 kHz/500 μsec
2-pole	1	120000 rpm	60000 rpm	30000 rpm
4-pole	2	60000 rpm	30000 rpm	15000 rpm
6-pole	3	40000 rpm	20000 rpm	10000 rpm
8-pole	4	30000 rpm	15000 rpm	7500 rpm

## 2.2 SMC20 模块 (6SL3055-0AA00-5BA3)

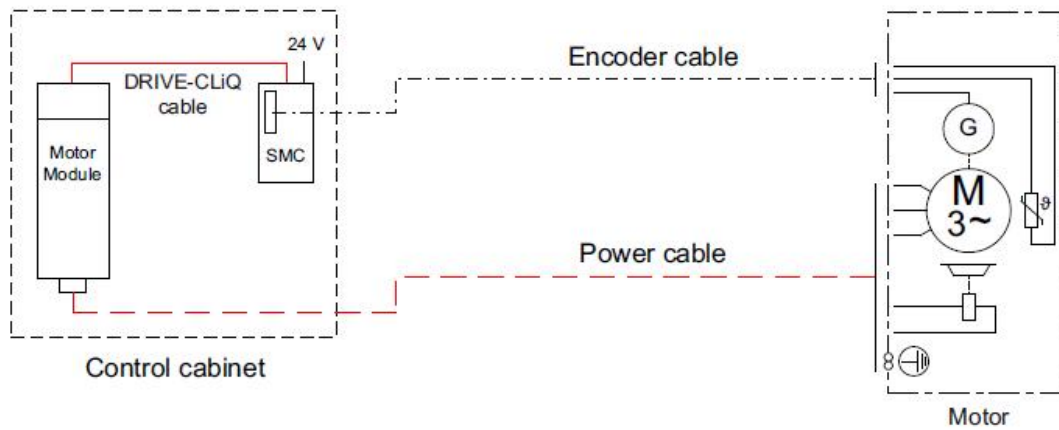
(1) 模块概览



图 4. SMC20 概览

## (2) 可处理的编码器信号

- 增量编码器 sin/cos 1 Vpp
- 绝对值编码器 EnDat 2.1
- SSI 编码器带增量信号 sin/cos 1 Vpp (版本号 2.4 及之后)
- 编码器供电电源 5 V DC/0.35 A
- 编码器增量信号的最大频率为 500 kHz
- SSI 传输波特率为 100 kBaud
- SMC20 模块和编码器之间的最大编码器电缆长度为 100 m (328 ft)。

此外，还可以借助温度传感器 KTY84-130 来检测电机温度信号。

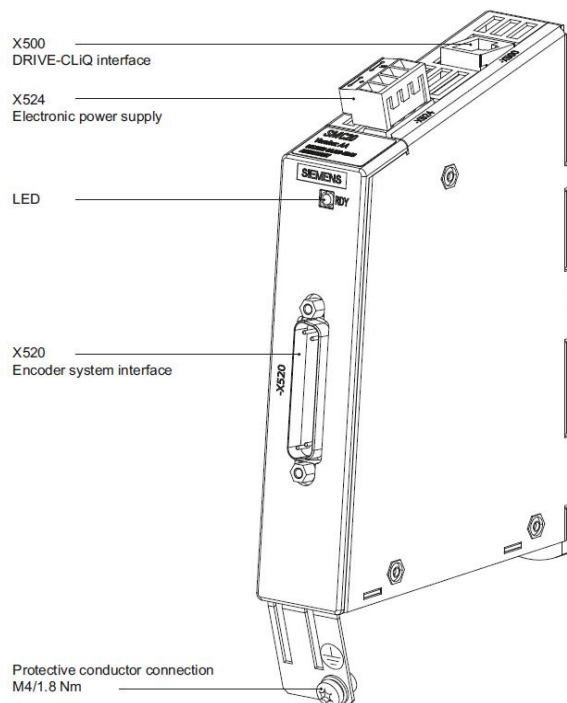
## (3) 设计

机柜安装式传感器模块 SMC20 标准提供有下列接口：

- 1 个 DRIVE-CLiQ 接口
- 1 个编码器接口，包括电机温度检测(KTY84-130)，通过 Sub-D连接器连接
- 1 个电子装置电源接口，通过 24 V DC 电源连接器连接
- 1 个 PE( 保护性接地) 接口

机柜安装式传感器模块 SMC20 的状态通过一个多色 LED 来显示。

机柜安装式传感器模块 SMC20 可以卡在符合 EN 50 022 标准的 35 x 15/7.5 DIN 导轨上。

## (4) SMC20 X520 接口定义

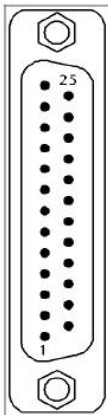

	Pin	Signal name	Technical specifications
	1	P encoder	Encoder power supply
	2	M encoder	Ground for encoder power supply
	3	A	Incremental signal A
	4	A*	Inverse incremental signal A
	5	Ground	Ground (for internal shield)
	6	B	Incremental signal B
	7	B*	Inverse incremental signal B
	8	Ground	Ground (for internal shield)
	9	Reserved, do not use	
	10	Clock	Clock, EnDat interface, SSI clock
	11	Reserved, do not use	
	12	Clock*	Inverted clock, EnDat interface, inverted SSI clock
	13	+ Temp	Motor temperature measurement KTY84-1C130 (KTY+) Temperature sensor KTY84-1C130 / PTC
	14	P sense	Sense input encoder power supply
	15	Data	Data, EnDat interface, SSI data
	16	M sense	Ground sense input encoder power supply
	17	R	Reference signal R
	18	R*	Inverse reference signal R
	19	C	Absolute track signal C
	20	C*	Inverse absolute track signal C
	21	D	Absolute track signal D
	22	D*	Inverse absolute track signal D
	23	Data*	Inverse data, EnDat interface, Inverse SSI data
	24	Ground	Ground (for internal shield)
	25	- Temp	Motor temperature measurement KTY84-1C130 (KTY-) Temperature sensor KTY84-1C130 / PTC

(5) 模块连接示例



图 5. SMC20 连接示例

**注意:**

- (1) SSI 波特率: 100kHz (6SL3055-0AA00-5BA2)  
100 - 250 (6SL3055-0AA00-5BA3)

- (2) 电流控制器时钟

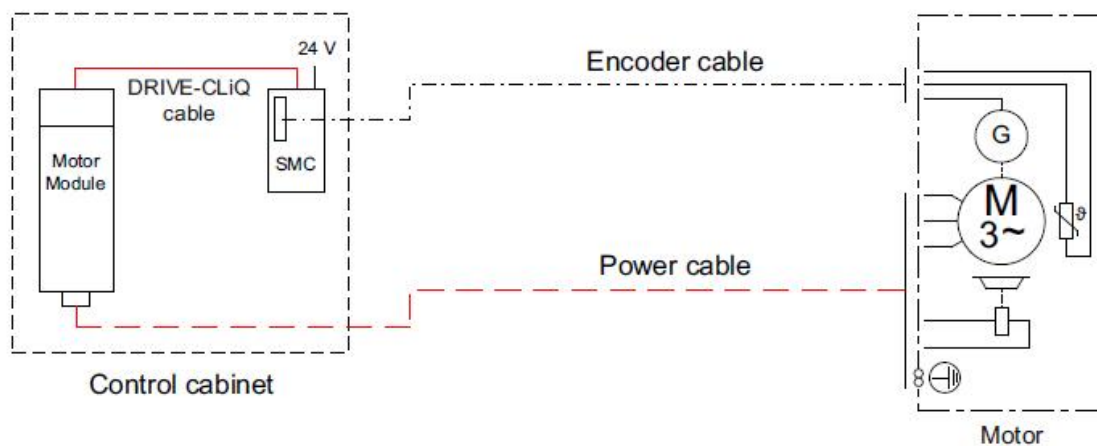
当使用电流控制器时钟为 31.25  $\mu$ s 时, 必须使用订货号为 SL3055-0AA00-5BA3。

**2.3 SMC30 模块 (6SL3055-0AA00-5CA2)**

(1) 模块概览



图 6. SMC30 概览

(2) 可处理的编码器信号

- 增量编码器 TTL/HTL
- SSI 编码器带有 TTL/HTL 增量信号
- SSI 编码器不带增量信号
- 输入阻抗
  - TTL 570  $\Omega$
  - HTL, 最大 16 mA
- 编码器供电 24 V DC/0.35 A 或 5 V DC/0.35 A
- 编码器频率, 最大 300 kHz

- SSI 波特率 100 ... 250 kBaud
- 限制频率 300 kHz
- 绝对位置分辨率 SSI 30 bit
- 最长电缆长度
- TTL 编码器: 100 m (328 ft) (仅双极性允许, 需用屏蔽双绞线)
- HTL编码器: 单极性100 m (328 ft) , 双极性 300 m (984 ft) 需用屏蔽双绞线
- SSI 编码器: 100 m (328 ft)

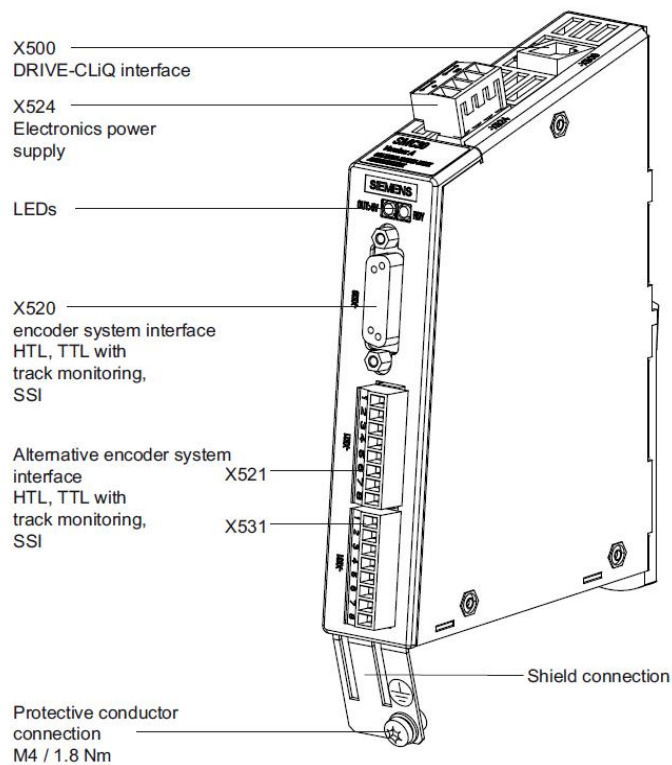
(3) 设计

机柜安装式传感器模块 SMC30 标准提供有下列接口:

- 1 个 DRIVE-CLiQ 接口
- 1 个编码器接口, 包括电机温度检测 (KTY84-130), 通过 Sub-D 连接器或端子连接
- 1 个电子装置电源接口, 通过 24 V DC 电源连接器连接
- 1 个 PE (保护性接地) 接口

机柜安装式传感器模块 SMC30 的状态通过一个多色 LED 来显示。

机柜安装式传感器模块 SMC30 可以卡在符合 EN 50 022 要求的35 x 15/7.5 DIN 导轨上。

(4) SMC30 接口定义

X520 接口定义

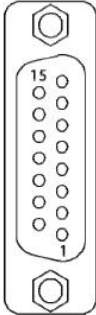
	Pin	Signal name	Technical specifications
	1	Reserved, do not use + Temp	Motor temperature sensing KTY84-1C130 (KTY+) Temperature sensor KTY84-1C130/PTC/bimetallic switch with NC contact
	2	Clock	SSI clock
	3	Clock*	Inverse SSI clock
	4	P encoder 5 V / 24 V	Encoder power supply
	5	P encoder 5 V / 24 V	
	6	P sense	Sense input encoder power supply
	7	M encoder (M)	Ground for encoder power supply
	8	Reserved, do not use - Temp	Motor temperature sensing KTY84-1C130 (KTY-) Temperature sensor KTY84-1C130/PTC/bimetallic switch with NC contact
	9	M sense	Ground sense input
	10	R	Reference signal R
	11	R*	Inverse reference signal R
	12	B*	Inverse incremental signal B
	13	B	Incremental signal B
	14	A* / data*	Inverse incremental signal A/inverse SSI data
	15	A / data	Incremental signal A/SSI data

Connector type: SUB-D female, 15-pin

X521/531 接口定义

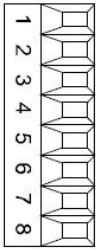
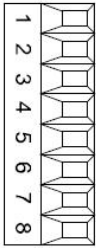
	Pin	Designation	Technical specifications
X521 	1	A	Incremental signal A
	2	A*	Inverse incremental signal A
	3	B	Incremental signal B
	4	B*	Inverse incremental signal B
	5	R	Reference signal R
	6	R*	Inverse reference signal R
	7	CTRL	Control signal
	8	M	Ground
X531 	1	P_Encoder 5 V / 24 V	Encoder power supply
	2	M_Encoder	Ground for encoder power supply
	3	- Temp	Motor temperature sensing KTY84-1C130 (KTY-) Temperature sensor KTY84-1C130/PTC/bimetallic switch with NC contact
	4	+ Temp	Motor temperature sensing KTY84-1C130 (KTY+) Temperature sensor KTY84-1C130/PTC/bimetallic switch with NC contact
	5	Clock	SSI clock
	6	Clock*	Inverse SSI clock
	7	Data	SSI data
	8	Data*	Inverse SSI data

Max. connectable cross-section: 1.5 mm<sup>2</sup>  
 When using unipolar HTL encoders, at the terminal block A\*, B\*, R\* must be connected to (jumper) M\_Encoder (X531)<sup>1)</sup>.

(5) 模块连接示例

连接示例 1: 带有参考信号的双极性 HTL 编码器



图 7. 连接示例

编码器连线必须使用屏蔽双绞电缆，以抑制电磁干扰。

连接示例 2: 带有参考信号的单极性 HTL 编码器

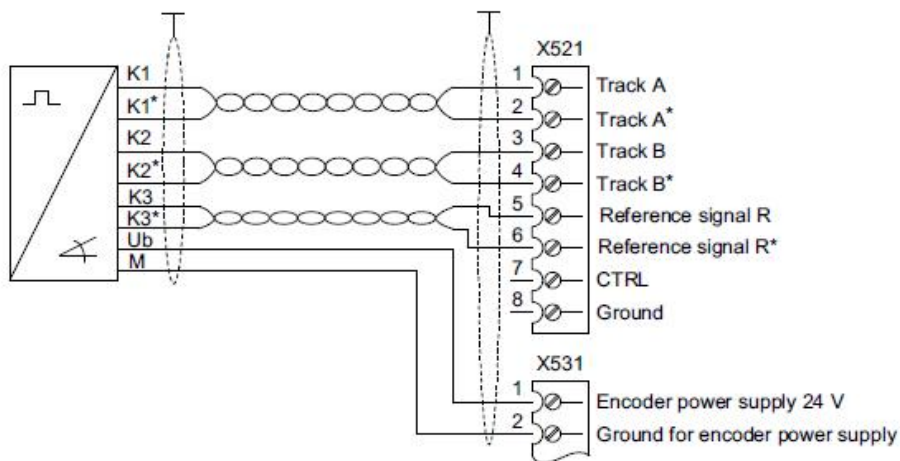

图 8. 连接示例

注意：单极性 HTL 编码器的 A\*,B\*应连接到 X531 上的 M\_Encoder 端子上。

### 3 安装在设备上的的编码器信号转换模块

安装在设备上的电柜外的测量系统可直接连接到外置传感器模块(SME20, SME25, SME120 及 SME125)，在北美遵循 NFPA 79 "工厂机械的电气标准。SME 检测这些测量系统并将所计算的数值转送到 DRIVE-CLiQ，在 SME 中不保存电机和编码器数据。

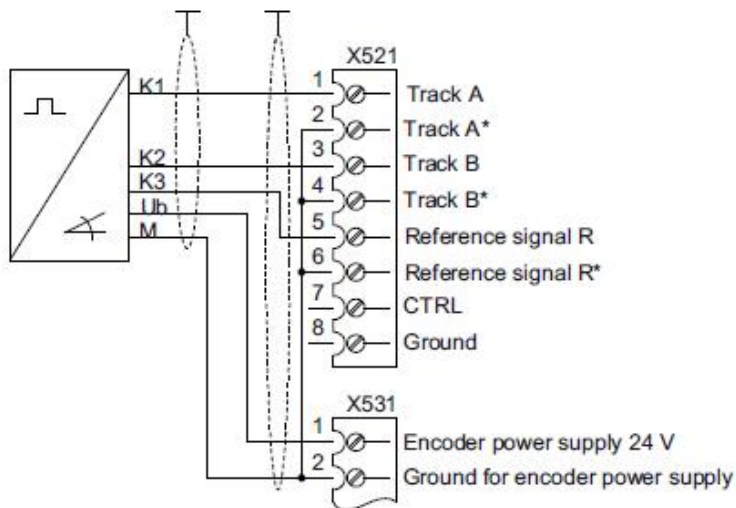
SME 模块提供编码器的供电，具有较高的防护等级（IP67），适于安装在柜外。



图 9. 模块概览

#### 3.1 SME20 模块（6SL3055-0AA00-5EA3）

(1) 可处理的编码器信号

可连接增量直接编码器系统带有 SIN/COS (1 Vpp) 及参考信号。  
使用适配电缆6FX 8002-2CA88-xxxx 连接电机编码器至 SME20。

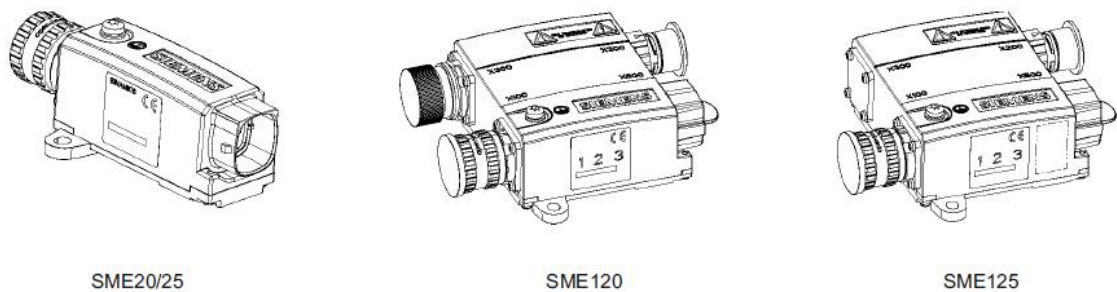
- KTY/PTC 温度传感器用于测量电机温度。
- 编码器模块仅适用于不带绝对轨迹信号的电机：
  - 感应电机(如：1PH)



– 带有磁极位置辨识的同步电机Synchronous (如：1FN, 1FW, 1FE)

SME20 中不保存电机及编码器数据。

(2) 编码器系统接口

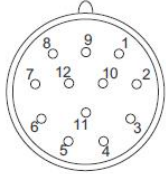
	Pin	Signal name	Technical specifications
	1	B*	Inverted incremental signal B
	2	P5	Encoder power supply
	3	R	Reference signal R
	4	R*	Inverted reference signal R
	5	A	Incremental signal A
	6	A*	Inverted incremental signal A
	7	-Temp	Temperature sensor connection <sup>1)</sup> KTY841-C130 or PTC
	8	B	Incremental signal B
	9	+Temp	Temperature sensor connection <sup>1)</sup> KTY841-C130 or PTC
	10	M	Ground for encoder power supply
	11	M	Ground for encoder power supply
	12	P5	Encoder power supply

Blanking plate for encoder system interface: Pöppelmann GmbH & Co. KG, Lohne,  
Order No.: GPN 300 F211  
connector kits, 12-pole, Order No.: 6FX2003-0SA12

(3) 模块连接示例



图 10. 连接示例

3.2 SME25 模块 (6SL3055-0AA00-5HA3)

(1) 可处理的编码器信号

可连接编码器 EnDat 2.1 或 SSI 带有 SIN/COS (1 Vpp) 增量信号，但不带参考信号。

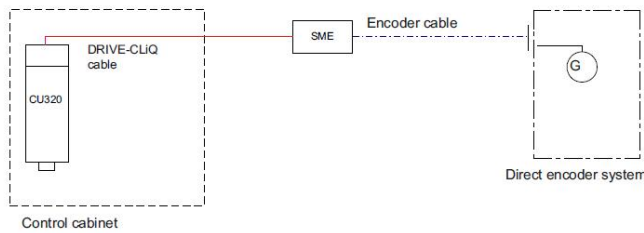
SME25 中不保存电机及编码器数据。

(2) 编码器系统接口

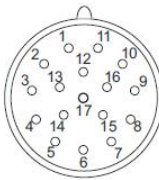
	Pin	Signal name	Technical specifications
	1	P5	Encoder power supply
	2	Reserved, do not use	
	3	Reserved, do not use	
	4	M	Ground for encoder power supply
	5	Reserved, do not use	
	6	Reserved, do not use	
	7	P5	Encoder power supply
	8	Clock	Clock, EnDat interface, SSI clock
	9	Clock*	Inverted clock, EnDat interface, inverted SSI clock
	10	M	Ground for encoder power supply
	11	Housing potential	
	12	B	Incremental signal B
	13	B*	Inverted incremental signal B
	14	Data	Data, EnDat interface, SSI data
	15	A	Incremental signal A
	16	A*	Inverted incremental signal A
	17	Data*	Inverted data, EnDat interface, Inverted SSI data

Blanking plate for encoder system interface: Pöppelmann GmbH & Co. KG, Lohne,  
 Order No.: GPN 300 F211  
 connector kits, 17-pin, Order No.: 6FX2003-0SA17

(3) 模块连接示例



图 11. 连接示例

3.3 SME120 模块 (6SL3055-0AA00-5HA3)

(1) 模块概览

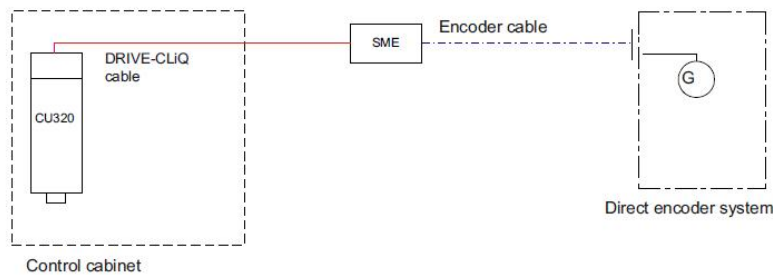

图 12. 模块概览

(2) 可处理的编码器信号

SME120 主要用于直线电机应用。可连接霍尔传感器盒确定直线电机的换向角位置。

SME120 可连接 SIN/COS (1 Vpp) 及参考信号的增量直接编码器，SME120 中不保存电机及编码器数据。

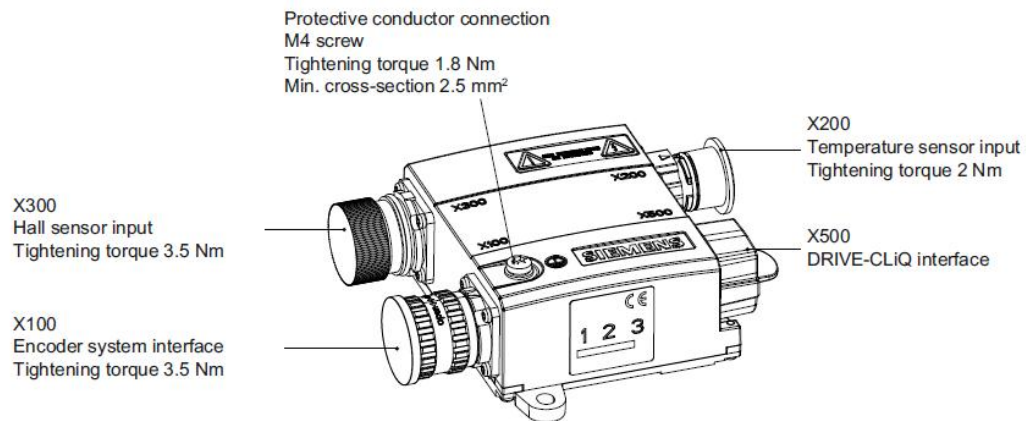
(3) 编码器系统接口

X100 接口:

	Pin	Signal name	Technical specifications
	1	B*	Inverse incremental signal B
	2	P5	Encoder power supply
	3	R	Reference signal R
	4	R*	Inverse reference signal R
	5	A	Incremental signal A
	6	A*	Inverse incremental signal A
	7	Reserved, do not use	
	8	B	Incremental signal B
	9	Reserved, do not use	
	10	M	Ground for encoder power supply
	11	M	Ground for encoder power supply
	12	P5	Encoder power supply

Blanking plate for encoder system interface: Pöppelmann GmbH & Co. KG, Lohne,  
Order No.: GPN 300 F211  
connector kit, 12-pin, Order No.: 6FX2003-0SA12

X200 接口:



Pin	Function	Technical specifications
1	-Temp	Temperature sensor connection KTY84-1C130/PTC/bimetallic switch with NC contact In linear and torque motor applications, connect the KTY84-1C130 motor temperature sensor here
2	+Temp	
3	+Temp	Temperature sensor connection KTY84-1C130/PTC/bimetallic switch with NC contact In linear and torque motor applications, connect the PTC triple element 1 or bimetallic switch here
4	-Temp	
5	+Temp	Temperature sensor connection KTY84-1C130/PTC/bimetallic switch with NC contact In torque motor applications, connect the PTC triple element 2 here
6	-Temp	
Connector kit, 6+1-pin, order number: 6FX2003-0SU07		

X300 霍尔传感器输入:

Pin	Signal name	Technical specifications
1	C	Absolute track signal C
2	C*	Inverse absolute track signal C
3	P5	Encoder power supply
4	M	Ground for encoder power supply
5	D	Absolute track signal D
6	D*	Inverse absolute track signal D
7	Not assigned	
8	Not assigned	
9	Ground	Ground (for internal shield)

(4) 模块连接示例

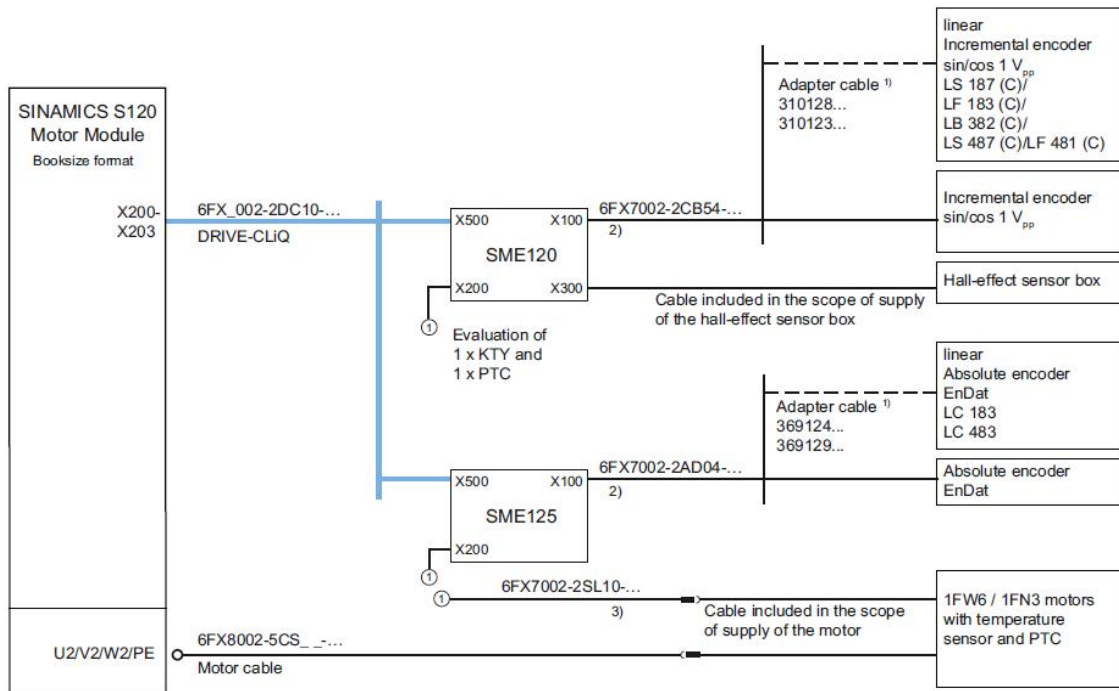

- 1) Cable can be ordered from supplier of linear scale.
- 2) max. length of encoder cable, see diagram in Chapter "Technical Data"
- 3) max. cable length between SME and motor connection: 10 m

图 13. 连接示例

### 3.4 SME125 模块 (6SL3055-0AA00-5KA3)

#### (1) 模块概览



图 14. 模块概览

#### (2) 可处理的编码器信号

SME125 主要用于直线电机应用。可连接霍尔传感器盒确定直线电机的换向角位置。

SME125 可连接 EnDat 2.1 或 SSI 带 SIN/COS (1 Vpp) 增量信号但不带参考信号的绝对值编码器，SME125 中不保存电机及编码器数据。

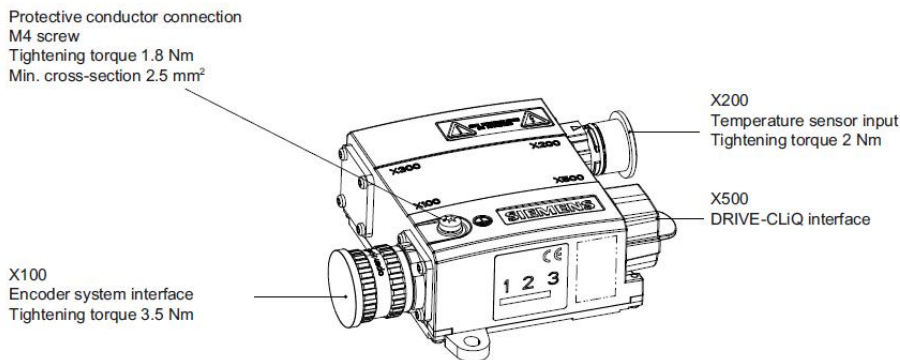
#### (3) 编码器系统接口

X100 接口:

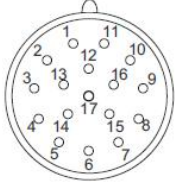
	Pin	Signal name	Technical specifications
	1	P5	Encoder power supply
	2	Reserved, do not use	
	3	Reserved, do not use	
	4	M	Ground for encoder power supply
	5	Reserved, do not use	
	6	Reserved, do not use	
	7	P5	Encoder power supply
	8	Clock	Clock, EnDat interface, SSI clock
	9	Clock*	Inverse clock EnDat interface Inverse SSI clock
	10	M	Ground for encoder power supply
	11	Housing potential	
	12	B	Incremental signal B
	13	B*	Inverse incremental signal B
	14	Data	Data, EnDat interface, SSI data
	15	A	Incremental signal A
	16	A*	Inverse incremental signal A
	17	Data*	Inverse data, EnDat interface, Inverse SSI data

Blanking plate for encoder system interface: Pöppelmann GmbH & Co. KG, Lohne,  
Order No.: GPN 300 F211  
connector kit, 17-pin, Order No.: 6FX2003-0SA17

X200 温度传感器输入:

Pin	Function	Technical specifications
1	-Temp	Temperature sensor connection KTY84-1C130/PTC/bimetallic switch with NC contact In linear and torque motor applications, connect the KTY84-1C130 motor temperature sensor here
2	+Temp	
3	+Temp	Temperature sensor connection KTY84-1C130/PTC/bimetallic switch with NC contact In linear and torque motor applications, connect the PTC triple element 1 or bimetallic switch here
4	-Temp	
5	+Temp	Temperature sensor connection KTY84-1C130/PTC/bimetallic switch with NC contact In torque motor applications, connect the PTC triple element 2 here
6	-Temp	

Connector kit, 6+1-pin, order number: 6FX2003-0SU07

(4) 模块连接示例

见 SME120。

如果您对该文档有任何建议，请将您的宝贵建议提交至[下载中心留言板](#)。

该文档的文档编号：**F0663**

## 附录一 推荐网址

### 驱动技术

西门子（中国）有限公司

工业业务领域 客户服务与支持中心

网站首页：[www.4008104288.com.cn](http://www.4008104288.com.cn)

驱动技术 下载中心：

<http://www.ad.siemens.com.cn/download/DocList.aspx?Typeld=0&CatFirst=85>

驱动技术 全球技术资源：

<http://support.automation.siemens.com/CN/view/zh/10803928/130000>

“找答案”驱动技术版区：

<http://www.ad.siemens.com.cn/service/answer/category.asp?cid=1038>

### 注意事项

应用示例与所示电路、设备及任何可能结果没有必然联系，并不完全相关。应用示例不表示客户的具体解决方案。它们仅对典型应用提供支持。用户负责确保所述产品的正确使用。这些应用示例不能免除用户在确保安全、专业使用、安装、操作和维护设备方面的责任。当使用这些应用示例时，应意识到西门子不对在所述责任条款范围之外的任何损坏/索赔承担责任。我们保留随时修改这些应用示例的权利，恕不另行通知。如果这些应用示例与其它西门子出版物(例如，目录)给出的建议不同，则以其它文档的内容为准。

### 声明

我们已核对过本手册的内容与所描述的硬件和软件相符。由于差错难以完全避免，我们不能保证完全一致。我们会经常对手册中的数据进行检查，并在后续的版本中进行必要的更正。欢迎您提出宝贵意见。

版权© 西门子（中国）有限公司 2001-2012 版权保留

复制、传播或者使用该文件或文件内容必须经过权利人书面明确同意。侵权者将承担权利人的全部损失。权利人保留一切权利，包括复制、发行，以及改编、汇编的权利。

西门子（中国）有限公司